



Quick Installation Guide

X3-Hybrid 5kW-10kW

II

Mounting Steps

- Mark position of six holes.
- Drill holes with $\phi 10$ drill. Depth: at least 60mm.
- Tighten the expansion tubes. Screw the expansion screws.

- Aim the upper side of the inverter to the top small hook of the bracket.
- Make the bottom of the inverter lean on the bracket.
- Press the inverter slightly toward the hole to make it firmly installed.

- Screw the set screw on the right-top of inverter tightly.

- If necessary, customer can install an anti-theft lock on the right-top of the inverter.

- Overview of Mounting

I

Packing List

III

PV and AC Connection

PV connection steps (PV cable size: 12AWG):

positive DC pin contact, negative DC pin contact, clamp contact, male plug, nut, tight nut, female plug.

- Align the halves connectors

AC connection steps (AC cable size: refer to table 1):

1. Remove the top-down cover.
2. Make AC wires.
3. Insert AC cable into Grid port through screw cap.
4. Connect the wire to the AC terminal in the inverter.

a. L-wire, N-wire connection
b. PE wire connection

Model	X3-Hybrid-5.0-D	X3-Hybrid-6.0-D	X3-Hybrid-8.0-D	X3-Hybrid-10.0-D
Cable	4-5mm ²	4-5mm ²	4-5mm ²	5-6mm ²
Micro-breaker	20A	20A	25A	32A

table 1

IV

EPS Connection (for E Version)

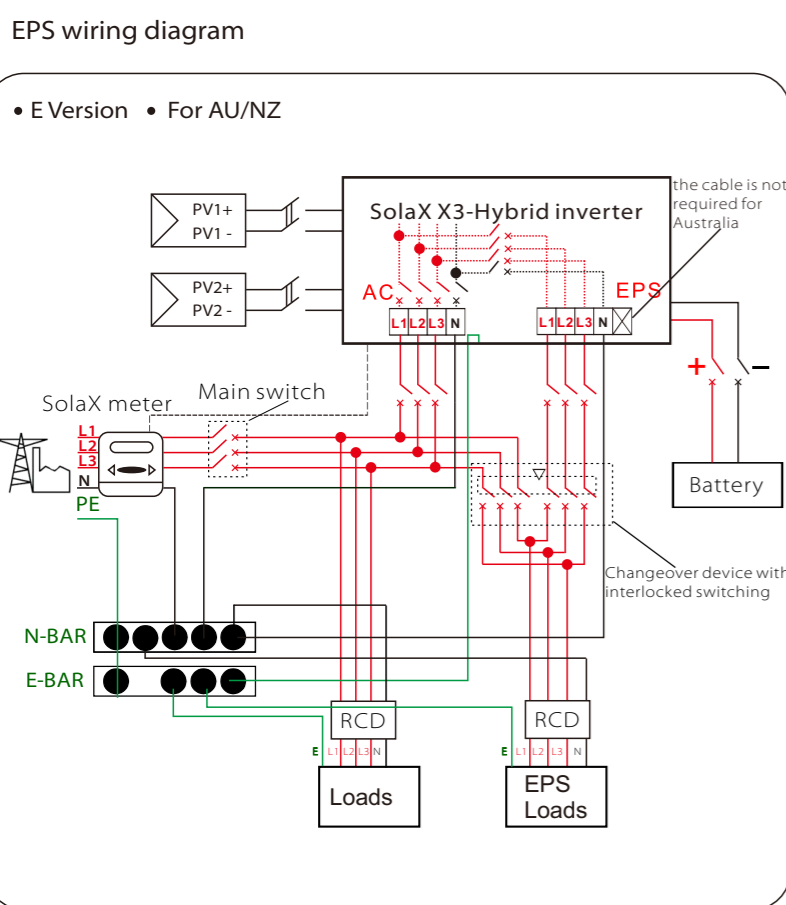

EPS connection steps:

1. Make wire (EPS cable size: refer to table 2)

For Australia/New Zealand

For other countries

Model	X3-Hybrid-5.0-D	X3-Hybrid-6.0-D	X3-Hybrid-8.0-D	X3-Hybrid-10.0-D
EPS Cable	$\geq 5\text{mm}^2$	$\geq 5\text{mm}^2$	$\geq 5\text{mm}^2$	$\geq 5\text{mm}^2$
EPS breaker	25A	25A	32A	32A

table 2: Cable and Micro-breaker recommended

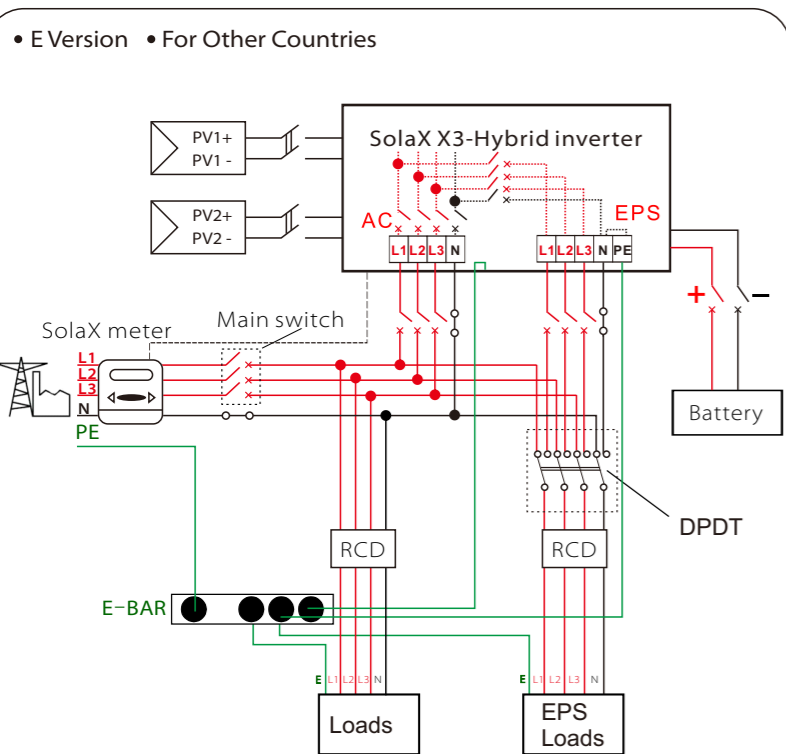

This function can be achieved manually or automatically according to user's preference.
For manual solution, please install an external switch.

2. Insert EPS cable into EPS port through screw cap.

Australia/New Zealand

other countries

Note: The N port at right should not be connected!

Note: Connect PE wire into N port at right!

V

Lithium Battery Connection (optional)

Battery connection diagram

Note: For lead-acid battery connection, please refer to Important Instruction for lead acid battery.

Battery breaker

Before connecting to battery, please install a nonpolarized DC breaker to make sure inverter can be securely disconnected during maintenance.

Model	X3-Hybrid-5.0-D	X3-Hybrid-6.0-D	X3-Hybrid-8.0-D	X3-Hybrid-10.0-D
Voltage	Nominal voltage of DC breaker should be larger than maximum voltage of battery.			
Current[A]	32A			

BMS PIN Definition

Communication interface between inverter and battery is CAN with a RJ45 connector.

PIN	1	2	3	4	5	6	7	8
Definition	NTC	GND	GND	BMS_CANH	BMS_CANL	GND	BMS_485A	BMS_485B

Note: The battery communication can only work when the battery BMS is compatible with the inverter.

A: Power Connection Steps:

Press down spring until it clicks audibly into place

wire strands

The fine wire strands must be seen in the chamber

B: Communication Connection Steps:

Step1: Disassemble the GEN/Meter /BMS cable gland.

Step2: Prepare a communication cable (without sheath) and insert the communication cable through the cable nut.

Step3: Assemble the cable gland and screw the cable nut.

Step4: Insert one RJ45 side of the cable into BMS port inside of inverter and the other side into R5485 or Can port of the battery.

BMS Port: The first RJ45 port from right

Meter connection diagram

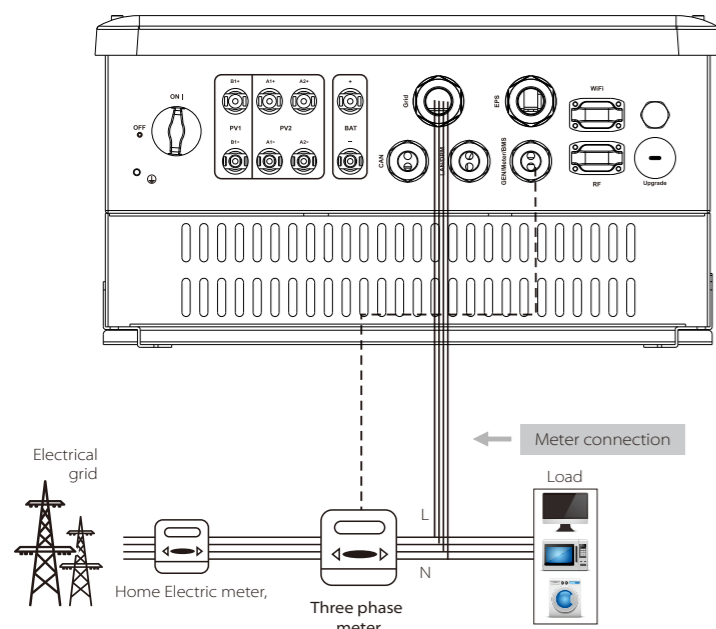

Communication interface between inverter and meter is RS485 with a RJ45 connector.

Meter connection step

- 1) Insert L/N wires and the 485 cable into the meter.
- 2) Insert the other side of the cable into the meter port on the inverter.
 - a. Unscrew the cable nut of Meter connector and insert two communication wires through it.
 - b. Strip the insulation from the communication cable, and then insert it into a 8 pin green terminal.
 - c. Insert the terminal into corresponding Meter terminal block inside of the inverter.

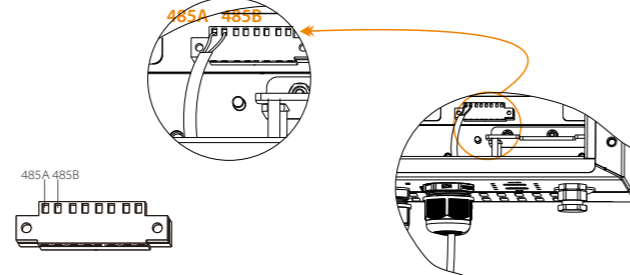
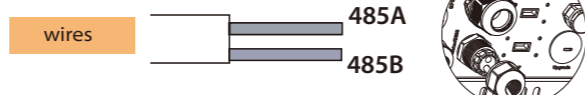

Earth Connection Steps(mandatory):

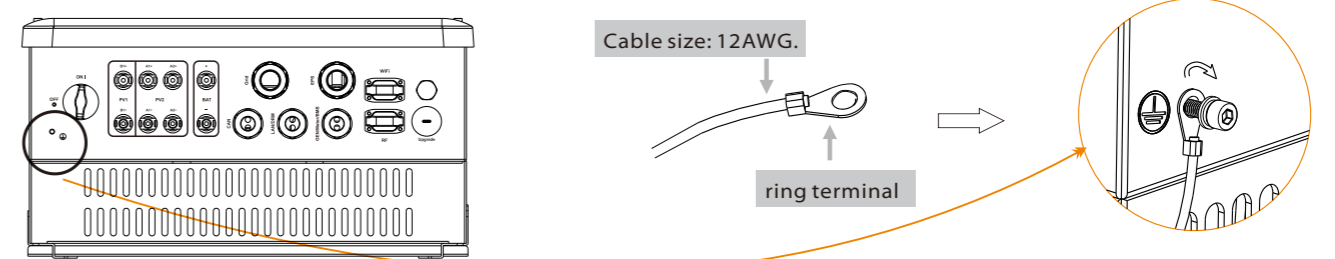

Start inverter

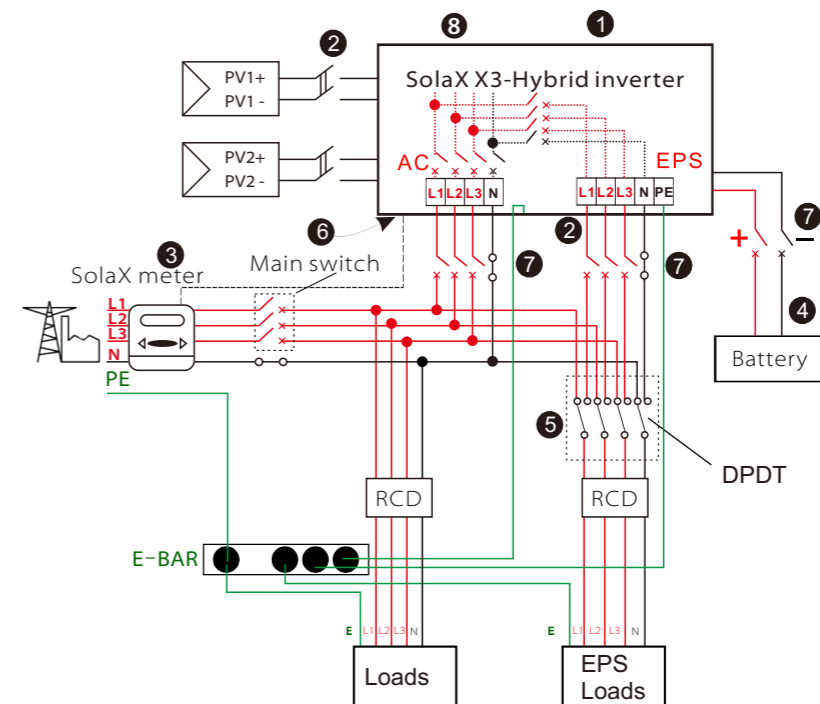

- 1 Ensure the inverter fixed well on the wall.
- 2 Make sure all the DC wirings and AC wirings are completed.
- 3 Make sure the meter is connected well.
- 4 Make sure the battery is connected well.
- 5 Make sure the external EPS contactor is connected well. (if needed)
- 6 Turn on the DC switch at the bottom of the inverter to "ON" position.
- 7 Turn on the AC switch, EPS switch and battery switch.
- 8 Press the "Enter" key for five seconds to exit Off Mode. (The mode is factory defaulted as Off Mode)

Inverter will start up automatically when the PV panels generate enough energy or the battery is discharging. Check the status of indicators and LCD screen. The left indicator should be blue and the indicator screen should display the main interface.

Firmware Upgrading

Preparation

Please ensure the inverter is steadily powered on. Inverter must connect PV panels and keep the battery on through whole procedure of upgrading. Please prepare an U-disk.

Warning! Make sure the PV input power is more than 180V (operate the upgrade on a sunny day), otherwise it may result in serious failing during upgrading.

- 1) Please contact our service support to get the update files, and extract it into your U-disk as following (Don't modify the file name):

"update\ARM\618.00098.00_Hybrid_X3G3_Manager_VX.XX.XX-XX.usb";
"update\DSP\618.00096.00_Hybrid_G3X3_Master_VX.XX.XX-XX.hex";

- 2) Press the "Enter" key for 5 seconds to enter Off Mode. Then unscrew the waterproof lid and insert U-disk into the "upgrade" port at the bottom of the inverter.

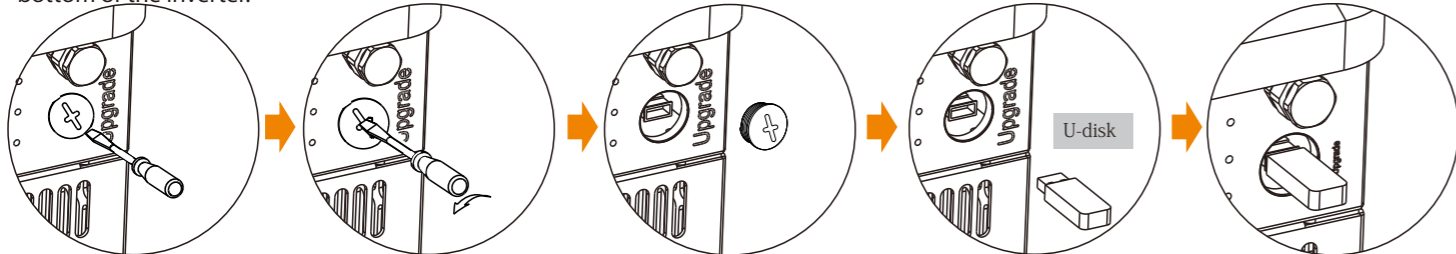

- 3) The LCD will be shown as the picture. Then press up and down to select the one that you want to upgrade and press "OK" to confirm to upgrade.

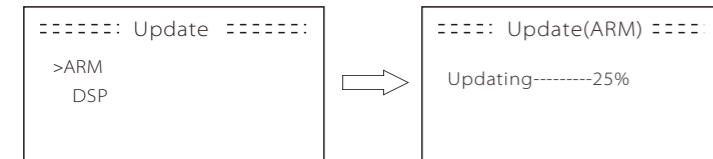

- 4) After the upgrade is finished, the LCD will display "succeed"(only for DSP upgrades), please remember to pull off the U-disk, screw the waterproof lid and press the "Esc" to return to the Main interface. Then press the "Enter" key to exit Off Mode.

Start Guide

1.Set language

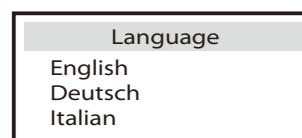

2.Set date time

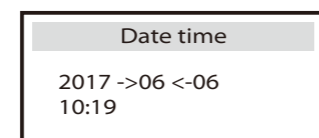

3.Set the safety standard



4.Set export control



This function allows the inverter able to control energy exported to the grid. There are user value and factory value. The factory value is default which can not be charged by user. The user value setting by installer must be less than the factory value.

5.Set work mode

There are 4 work modes for choice. Self use/ Back up mode/ Feed in Priority/ Force Time Use

Parameter	Comment
Self Use (default)	The PV generated power will be used to supply the local loads firstly, then to charge the battery. The redundant power will export to the public grid. When there is no PV supplied, battery will discharge for local loads firstly, and grid will supply power when the battery capacity is not enough.
Back Up Mode	Battery will stop discharging to keep higher capacity when the grid is on. Only when the grid is off and PV energy is not enough, battery will start to discharge to keep the emergency load working normally. This work mode applies to the area where suffering from blackout regularly.
Feed in Priority	The priority of inverter output power is: supplying the load → feeding to the grid → charging the battery. This work mode applies to the area with high feed-in tariff.
Force Time Use	In this work mode there are two charge periods charging time can be set flexibly, and it also allows to select whether charge from the grid or not.

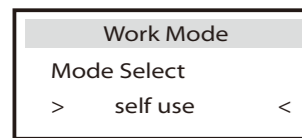

6.Set EPS system(For E Version only)

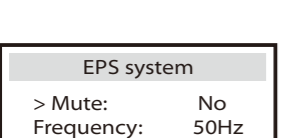

X3-Hybrid inverter with E Version can work on the EPS mode. EPS parameters can be set as below.
- "Mute" means you can set the warning of system which has entered EPS mode.
- "No" means there will be a buzzing and it is the default value.
- "Yes" means you choose to shut down the warning function.

Besides, if the buzzing is sharp, it means EPS output is over loads. Frequency "here can be set 50Hz or 60Hz please based on correlative loads.

7.Set relay control (The function is being developed)

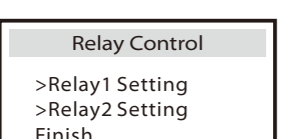

Relay Control is an optional function which can control designated load intelligently by consuming the surplus energy when feed in power reaches certain value. This function can only be achieved with solax product "Smart Plug". For specific operation, please refer to "Smart Plug user manual".

Monitoring Operation

Solax provides two ways for users to choose: Wifi(optional) and Ethernet(LAN)

Wifi(optional)

Inverter provides a Wifi port which can collect data from inverter and transmit it to monitoring-website via a Pocket WiFi. (Purchase the product from supplier if needed)

Diagram

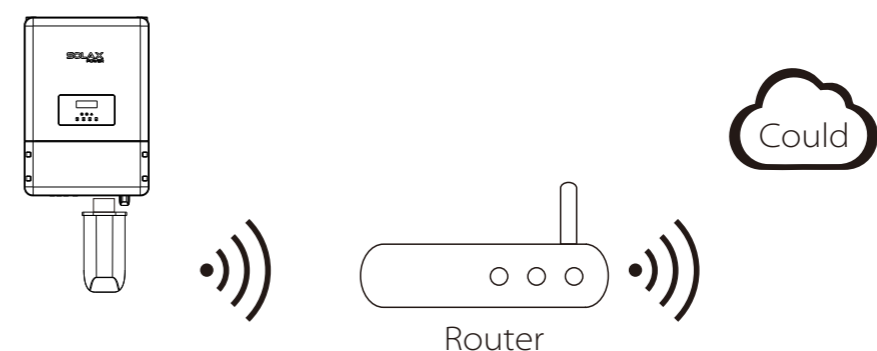

WiFi Connection Steps:

- Step1. Plug Pocket Wifi into "WiFi" port at the bottom of the inverter.
- Step2. Build the connection between the inverter and router.
- Step3. Create an user account online. (Please check the Pocket WiFi user manual for more details.)

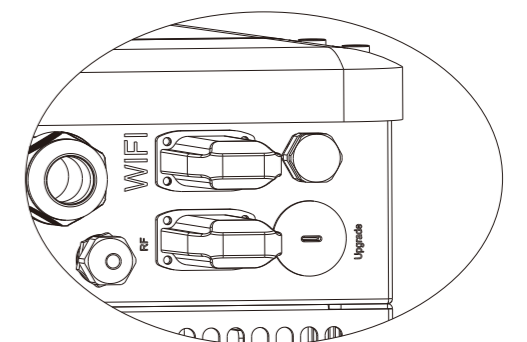

Ethernet(LAN)

LAN communication is the standard communication interface. It can transmit the data between the router and inverter via the local network.

Application Occasion

This function is applicable for the below situation:
When the wifi signal is too weak to transmit data, user can use LAN port for the monitoring with a data cable.
Note: The wifi module still needs to be connected when using LAN connection.

LAN PIN Definition

Communication interface between inverter and router is RS485 with a RJ45 connector.

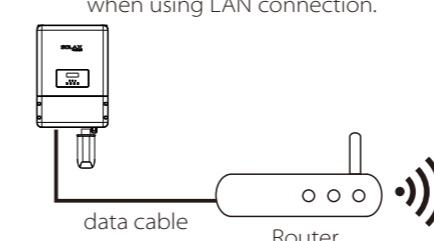

Pin	1	2	3	4	5	6	7	8
TX+								
TX-								
RX+								
X								
X								
RX-								
X								
X								

LAN Connection Steps:

Please refer to BMS connection steps (for user manual page32) for LAN connection. Please kindly noted the PIN definition and port position will be slightly different.

